



# Design and manufacture a novel tool in the incremental sheet metal forming process and its effects on the process parameters

E. Haghani, A. Gheysarian and M. Honarpisheh\*

Faculty of Mechanical Engineering, University of Kashan, Kashan, Iran

---

**Article info:**

Received: 00/00/2000

Accepted: 00/00/2018

Online: 00/00/2018

**Keywords:**

Incremental forming,

rotary tool,

Thickness variation,

Forming force.

**Abstract**

One of the methods for making prototypes is incremental forming process. In this method, the forming tool, performs a pre-programmed movement by the CNC machine and runs the desired path. This modernization process is used in the automotive, aerospace, military, medical and other industries. One of the most influential parameters in this process is forming tool. This parameter is effective in forming forces, surface roughness, sheet formability and thickness distribution. In this study, the forming tool was investigated and rotating geometry tool was compared with a rigid tool. Also, the effects of step down, feed rate and spindle speed were investigated on the forming force, surface roughness and thickness distribution by comparing mentioned forming tools. The results indicate that the forming forces, sheet surface quality and thickness changes increase with increasing step down and feed rate. Using the rotary tools improves the forming forces, surface roughness and thickness distribution rather than the non-rotating tool.

---

## 1. Introduction

Nowadays, the production of components with high plasticity and elasticity is one of the most important items in the production of industrial parts. For this reason, it is important to examine the conditions of forming and to improve this conditions to optimize the operation. In this process, the tool moves on the sheet in a predefined path and begins to shape it. This process involves two methods, the simplest method of incremental sheet forming (ISF) process is single-point incremental forming

(SPIF), which uses only one forming tool to form components and the other method is double-sided incremental forming (DSIF), which uses two forming tools to form components. In this method, at any moment of time, one of these tools will be forming the component and other one will act as support. Jesweit et al. [1] introduced a new method of asymmetric sheet shaping and called it an asymmetric incremental forming. According to the researches, the forming forces increases by increasing the vertical step, tool diameter, wall angle and initial thickness of sheet [2]. Silva et al. [3] reviewed

---

\*Corresponding author

Email address: honarpishe@kashanu.ac.ir

the formability of hole-flanging by SPIF. Montanari et al. [4] compared the relative performance of hole-flanging by incremental sheet forming and conventional press-working. Ambrogio et al. [5] introduced that magnesium has low formability at room temperature. Increasing the temperature up to 300 °C increases the formability of the magnesium sheet. Manco et al. [6] investigated the effects of tool diameter, vertical pitch, thickness and wall angle on the minimum thickness in the incremental forming by controlling and changing the design. Provided equations shown that tool diameter has a significant influence on the minimum thickness and minimum thickness increased with increasing the vertical pitch. Mirnia et al. [7] investigated the effect of tool diameter and vertical step on the thicknesses changes in a truncated cone. They reported that the elasticity increases and thickness decreases by increasing the tool diameter, as well as increasing the vertical step to a specific amount improve the thinning. They analyzed the surface roughness of formed parts by incremental forming [8]. Frattini et al. [9] investigated the effect of some mechanical properties of materials on the formability and compared both traditional and incremental forming. They reported that the main parameter on the formability is strain hardening. Iseki et al. [10] provided an approximate analysis to analyze the formability, forming forces and strain distribution. This analysis was performed by using deformation plane strain model and forming limit diagram. Iseki et al. [11] developed a gradual multi-stage forming machine by using spherical and cylindrical roller to form the vertical wall surfaces of thin rectangular panels. Filice et al. [12] showed increasing in the formability of the sheet due to local plastic deformation in the area around the tool and determined the forming limit curve by designing the experiments. Attanasio et al. [13] tried to optimize the tool path in positive incremental forming process. The purpose of this work was to provide an empirical assessment of the instrument's path. Young et al. [14] investigated the effect of input parameters on the wall thickness variations in single-point incremental forming process. They showed that

double-pass forming produces the parts that thin to failure with single-pass techniques. Hussain et al. [15] investigated the effect of input parameters on the formability of pure titanium sheet by using incremental sheet metal forming. Vertical step and the diameter of the tool were studied parameters in this study. The results showed that by increasing step down the formability decreases linearly and also by increasing the diameter of the tool and feed rate it is reduced. Hamilton et al. [16] investigated the effects of feed rate on the thicknesses distribution in the incremental sheet metal forming. Tests were completed on the Al3003 sheet with a maximum feed of 8890 mm/min and it was observed that this parameter does not have a significant effect on the thicknesses distribution. Kurra et al. [17] investigated the effect of process parameters on the roughness and time by using Design expert software and RSM method and by using NSGA-II a multi-objective optimization, was performed on the responses. Wenke Bao et al. [18] investigated the formability of AZ31B alloy and evaluated the influence of electropulse-assisted incremental forming (EAIF) on this parameter.

The experimental results showed that by increasing the root mean square (RMS) current density of electropulse, the electroplastic effect increase and the forming limit angle in EAIF have been up to 72° from the previous 39.6° without electropulse. It is found that the AZ31B dynamic recrystallization (DRX) temperature and accelerate of the DRX progress reduced by using electropulse, and it can improve the formability of the sheet by restrain the crack growth of the tested materials. Kurra Suresh et al. [19] by using finite element simulations evaluated the formability of the sheet in incremental forming process and compared the results with experimental tests. Senthil et al. [20] by Numerical Analysis of incremental sheet metal forming process evaluated the formability of AZ61A Magnesium Alloy. Mugendiran et al. [21] investigated the formability and thickness distribution on AA5052 aluminum alloy by incremental forming process. They showed that cone had higher forming limit than square cup and the thickness after forming was better in cone shapes than in square cups. McAnulty et al.

[22] investigated the effect of process parameters such as step down, feed rate, spindle speed and etc on the formability in the incremental sheet metal forming. Uheida et al. [23] investigated the impact of tool velocity on mechanical and thermal process loads in incremental forming of titanium sheets. They showed that higher speeds corresponded to higher temperatures and lower forces. Afonso et al. [24] investigated the formability of tunnel type part in incremental sheet metal forming. The goal was increasing the flexibility and maximum part size and reducing both the need of post-processing operations and material waste. The study finished with the manufacture of some more elaborate geometries, testing and validating the tunnel incremental forming concept to be used in freeform parts. Incremental forming process of explosive-welded multilayer is one of the attractive field which used in recent years. Sakhtemanian et al. [25] evaluated the effects of input parameters such as layer arrangement in the incremental forming process of low-carbon steel/CP-titanium bimetal. Experimental study on the process parameters of incremental forming of explosively-welded Al/Cu bimetal was performed by Gheysarian et al. [26]. Honarpisheh et al. [27] used response surface methodology to optimize the single point incremental forming of Al- 1050/ Cu bimetal sheet. Honarpisheh et al. [28] evaluated the effects of process parameters in the incremental forming process of Al/Cu bimetal, numerically and experimentally. Honarpisheh et al. [29] evaluated the effects of input parameters on the outputs in the hot incremental forming of Ti. In this study, the heat is localized to the contact point of the sheet and the instrument and transmitted by the electric current. Honarpisheh and Gheysarian. [30] Optimized and investigated the effect of the initial parameters on the incremental forming process. Sakhtemanian et al. [31] Examined the effects of ultrasonic vibration as one input parameter on the incremental forming process of bimetal sheet. Sakhtemanian et al. [32] Investigated the mechanical and geometrical properties of St/CP-titanium bimetal sheet during the single point incremental forming process.

There are many studies in the field of process parameters and formability of metal sheet by incremental forming until now.

This article evaluated the effect of rotary forming tool on the incremental sheet metal forming process which is the first time that this work has been done.

## 2. Principle and equipment of experimental setup

The rotary and non-rotary forming tools, sheet, holder, CNC milling machine and KISTLER 9257B dynamometer were used for this process (Fig. 1). The sensor of KISTLER 9257B dynamometer is located under the mold and on the CNC milling plate to measure the forming force. Then the sheet is clamped on the mold and the tool starts to execute the predefined motion. This tool moves through the CNC machine on a predetermined path and starts to forming the used sheet. The dimensions of samples were 160×160×2 mm. The tool motion is controlled numerically in the incremental forming process. CAD software is used to provide the required geometry and then the CAD file entered to the CAM software (POWERMILL). Finally, G-codes were obtained from the generated tool path to the CAM software and transferred to the CNC machine.

### 2.1. Material and tools

#### 2.1.1. Tools

So far, a lot of studies have been done with the use of stripping tools on the incremental forming process. In this study, tools with rotating geometry are used. The rotary tool reduces the friction between the tool and the sheet. So, the surface conditions and the formability of the sheet improves. For this purpose, the geometry of the tool is drawn up in a design software, which is visible in the Figure 2. In this geometry, the balloon can be rotated freely in any direction. In the rotary tool the ball can be freely moved by contacting the sheet in any direction but in the usual tool, the sheet was formed by rotation of the tool that this action cut some of the materials from surface (Fig. 3). Also, the direction of tool

and ball rotation on the sheet is effective in this category.

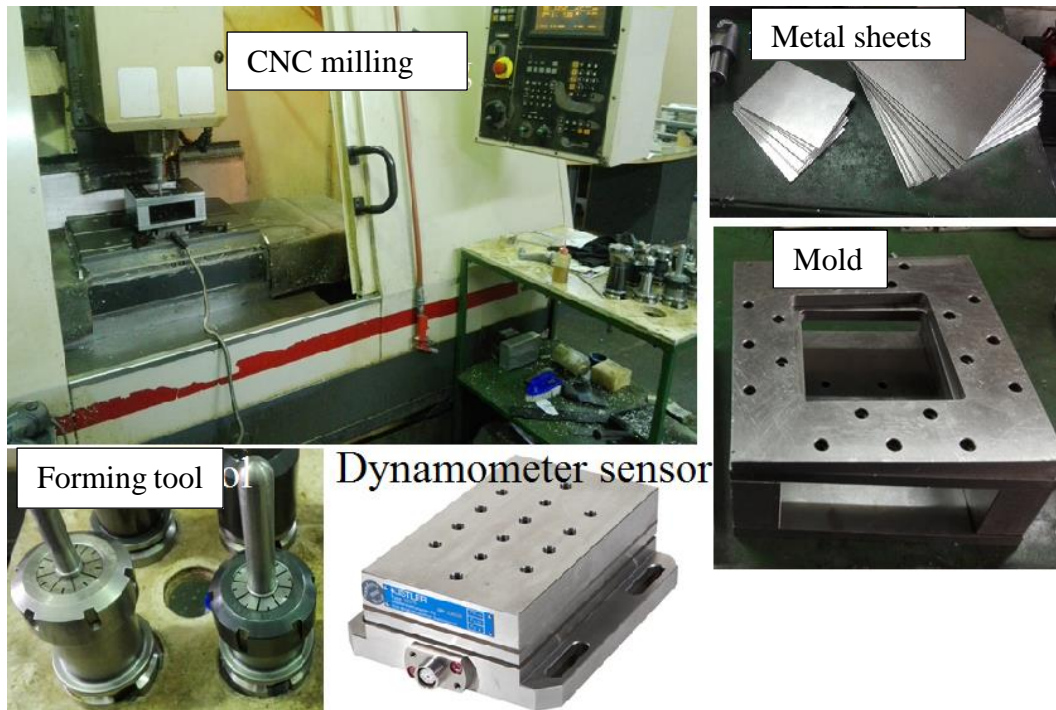

Fig. 1. The used equipment in this study

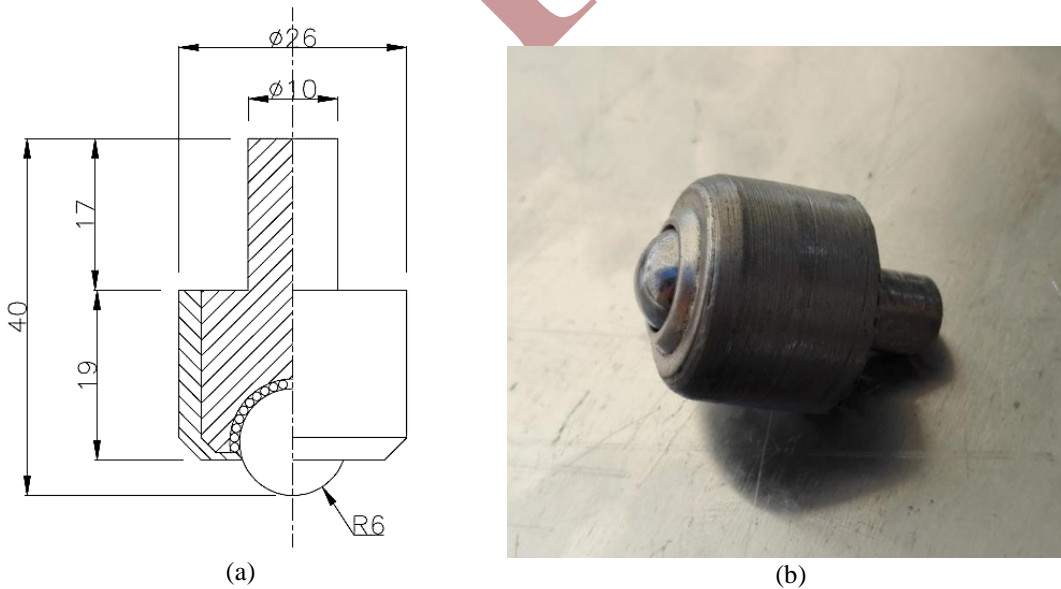
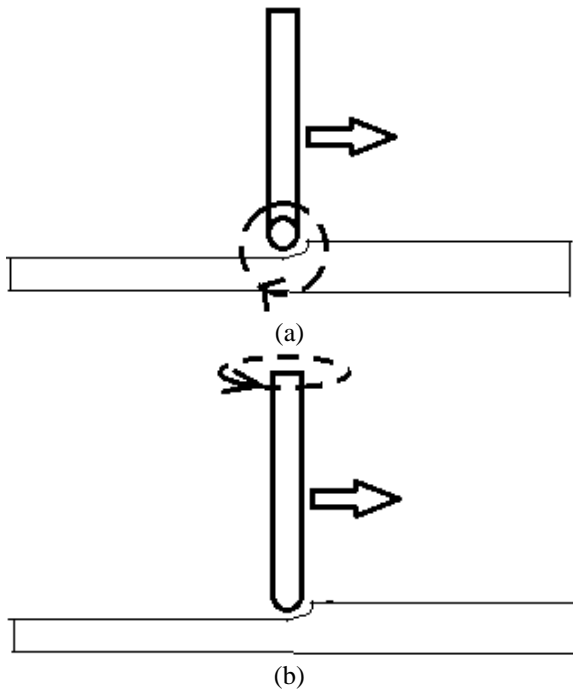

Fig. 2. Design of new tool (a) design model for tool (b) product tool



**Fig. 3.** Forming by any tool and closing method of rotary tool in the CNC (a) rotary tool (b) non- rotary tool

**2. 1. 2. Materials**

According to the design of experiments by DESIGN EXPERT software, 21 slides of aluminum 1050 sheets in 172×172×1.5 mm with six holes in 8 mm diameter around the plate is used in this process. To reduce the friction between tool and sheet, SAE- 40 liquid oil is used as lubricant.

**2.2. Design of part**

In this study, the pyramid geometry (Fig. 4) was developed in incremental forming process. The tool path (G codes) extracted from CAD model by POWER MILL software and transferred to the controller of CNC machine by CIMCO software.

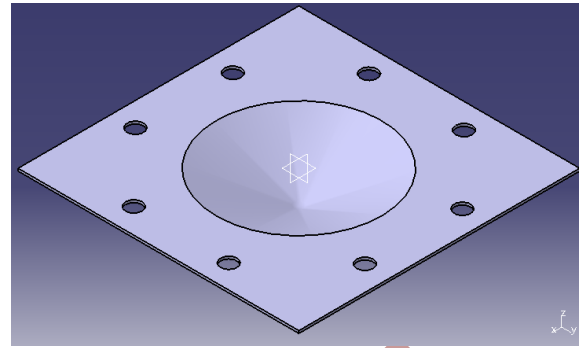

**Fig. 4.** Pyramid geometry

**2.3. Process parameters and design of experts**

At the beginning of each process an appropriate design is needed to carry out the required tests that determines and investigates the proper distribution of each parameter. In this test, the vertical step, spindle speed, type of tool and feed rate were selected as input parameters. For the parameters of vertical step, as well as feed rate, 3 values were considered and in the fixed instrument (old tool) for checking the spindle speed, 4 speeds were considered and compared to the two instruments (Table 1). According to the design of experiments there are 21 different states that should be performed in this process (Table 2).

**Table 1. Used parameters**

Input parameters	Level 1	Level 2	Level 3	Level 4
Tool model	old	new		
Spindle speed (N)	100	300	600	1000
Feed rate (F)	400	600	800	
Step down (dz)	0.25	0.5	0.75	

**Table 2. Design experiments**

Design Experiment	Tool	N	dz	F	Name
1	Roller ball	100	0.25	400	R1-25-400
2	Roller ball	100	0.25	600	R2-25-600
3	Roller ball	100	0.25	800	R3-25-800
4	Roller ball	100	0.5	400	R4-05-400
5	Roller ball	100	0.5	600	R5-05-600
6	Roller ball	100	0.5	800	R6-05-800

7	Roller ball	100	0.75	400	R7-75-400
8	Roller ball	100	0.75	600	R8-75-600
9	Roller ball	100	0.75	800	R9-75-800
10	Constant	1000	0.25	400	C1-25-400
11	Constant	1000	0.25	600	C2-25-600
12	Constant	1000	0.25	800	C3-25-800
13	Constant	1000	0.5	400	C4-05-400
14	Constant	1000	0.5	600	C5-05-600
15	Constant	1000	0.5	800	C6-05-800
16	Constant	1000	0.75	400	C7-75-400
17	Constant	1000	0.75	600	C8-75-600
18	Constant	1000	0.75	800	C9-75-800
19	Constant	100	0.5	800	C10-n100-05-800
20	Constant	300	0.5	800	C11-n300-05-800
21	Constant	600	0.5	800	C12-n600-05-800
22	Constant	1000	0.5	800	C13-n1000-05-800

In this table, R is a sign of rotating tool, C is an indication of the old tool, n is the spindle speed and tests 19 to 22 are used to determine the effect of spindle speed on the results.

### 3. Perform tests and measure the output parameters

In this study, the experiments were conducted to investigate the effect of input parameters on forming force, surface roughness and thickness distribution as output parameters. Experiments were conducted to obtain the lowest forming forces, less surface roughness and lowest thickness variations, and the results were presented. Sheet image while forming and

photos of some shaped sheets are shown in Fig. 5.

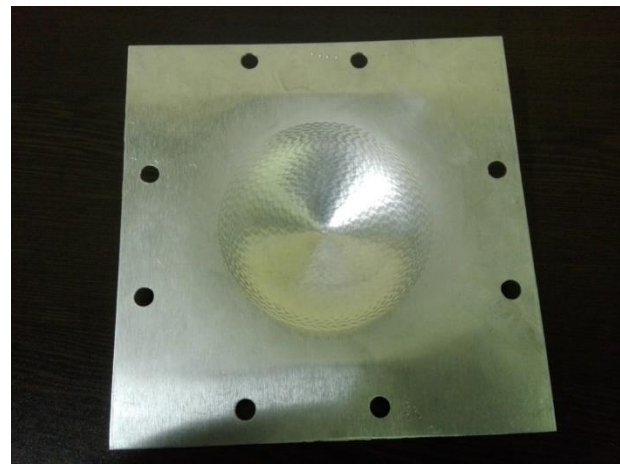

(a)



(b)

Fig. 5. (a) Formed sheets (b) forming process

### 4. Results and discussion

In this study, the effect of step down, feed rate, spindle speed and type of tool, have been investigated on the forming forces, thickness distribution and surface roughness. To measure the surface roughness, the roughness device traverses the path from B to C and for measuring the thickness distribution, the CMM<sup>1</sup> device

<sup>1</sup> Coordinate measuring machine

(Poly CMM sky model) traverses the path from A to C and provides results (Fig. 6).

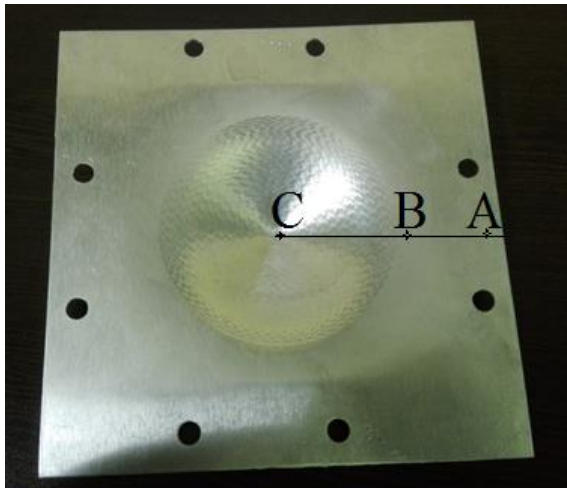

Fig. 6. Surface roughness and thickness distribution measuring path

**4.1. Effect of vertical step, feed rate and spindle speed on the forming forces**

In Figures 7 and 8, the results of investigating the effect of feed rate and vertical step on the forming forces are presented for two model tools that used in this study. The results indicate that

increasing vertical steps and feed rate increased the forming forces and the effect of the vertical step is much higher than the feed rate. Mirnia and Mollaei [7] referred to the same issues and stated that as the vertical step increased, the forces of formation would increase. This is due to the increase in the volume of the material being shaped and also the increase in the strain rate in the desired sheet. In fact, with the increase of the vertical step and the feed rate, a larger amount of material is changed and the strain is increased and with increasing the stress, the forming forces are increased. Spindle speed does not have a significant effect on the forming forces in the incremental forming but the forming forces decreased by increasing the spindle speed because the temperature at the contact point was increased and the plasticity was comfortable and in the new tool this parameter has no effect because the ball is in the contact with sheet and it can rotate freely in any direction. Also the results show that, in rotary geometry tools, shaping forces are reduced due to friction reduced between the tool and the sheet and provide better conditions for the forming process.

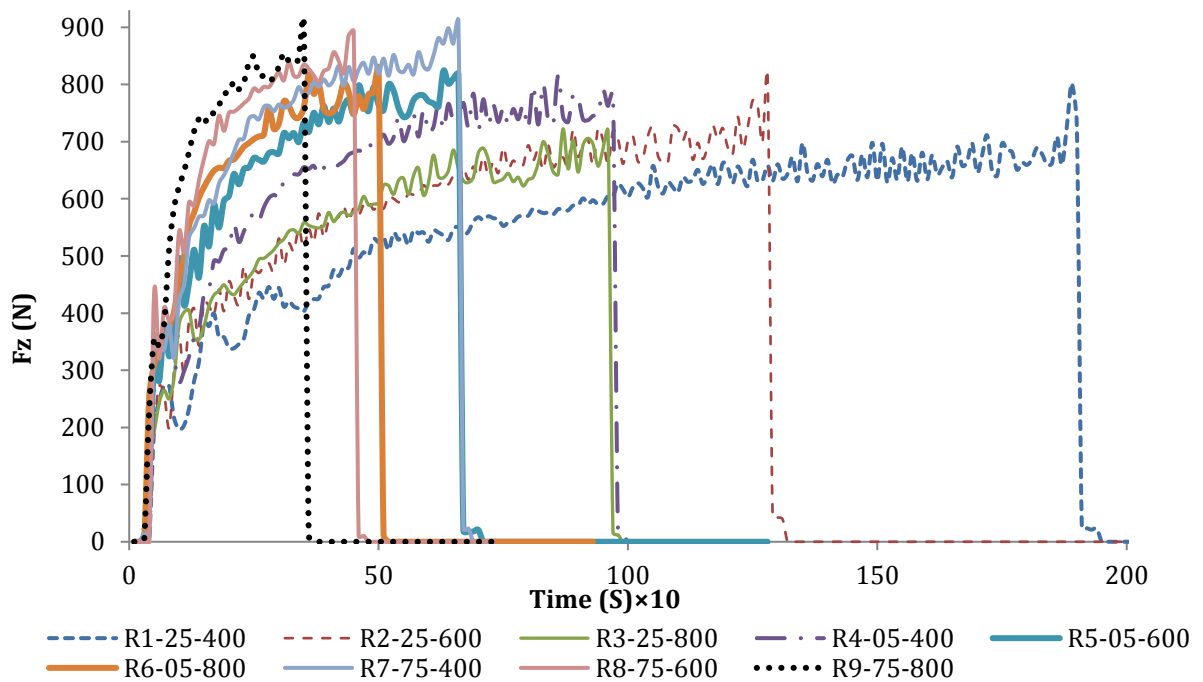
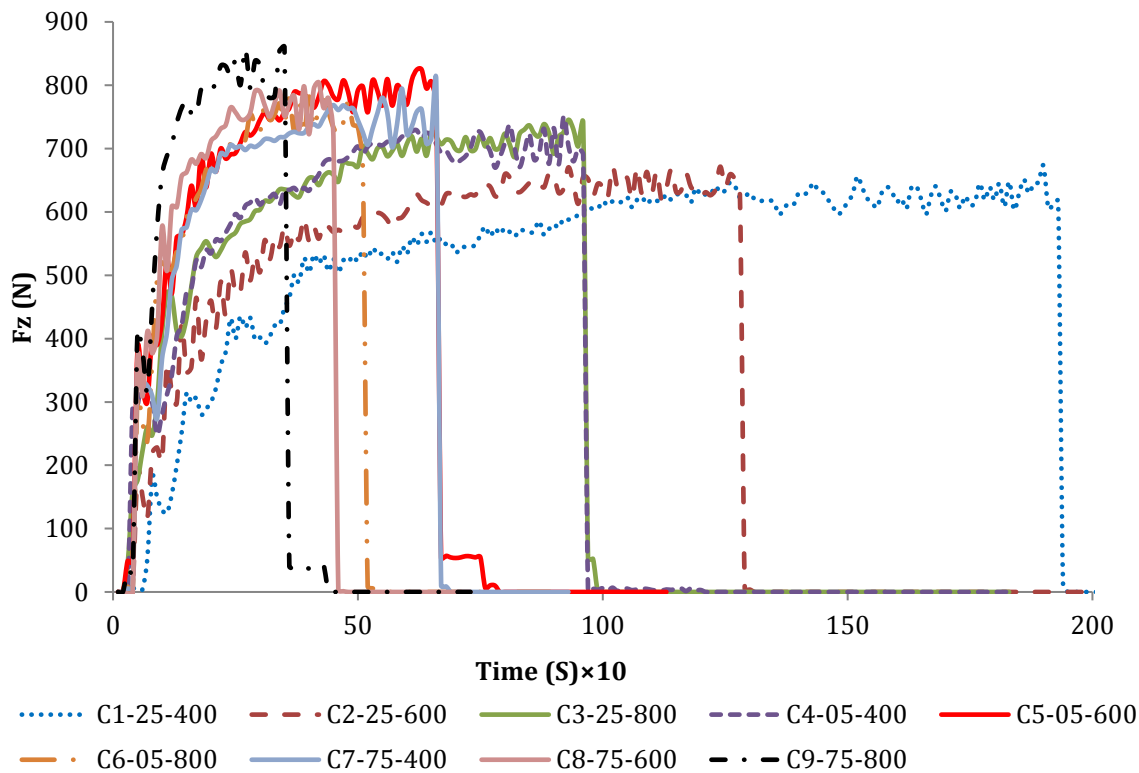
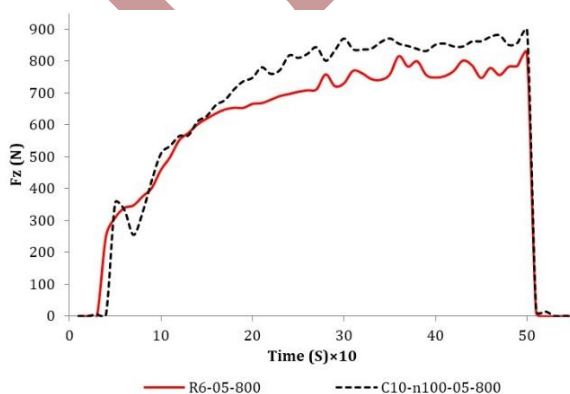

Fig. 7. Effect of feed rate and step down on the forming forces by rotational tool



**Fig. 8.** Effect of feed rate and step down on the forming forces by Non-rotating tool

According to studies, the spindle speed does not have a significant effect on incremental forming, but for the comparison of the two tools with each other, two tests should be selected with the same conditions in each case. A review of the experiments showed that tests R6 and C10 have the same conditions for comparing the two tools. The results of this comparison indicate that forming forces reduced by using the rotary tool (Fig. 9).



**Fig. 9.** Forming forces comparison for two rotational and non-rotational tools

#### 4.2. Effects of input parameters on surface roughness and the comparison of the effect of tools

In this process, the lubricant is used to improve the performance of the tests. The oil color, after testing with two tools, is visible in Fig. 10.

As shown in the figure, the oil has a common color in the rotary tool because the ball can be freely moved by contacting the sheet in any direction but in the usual tool, the sheet was formed by rotation of the tool that this action cut some of the materials from surface and cause the color of the oil to darken. The direction of tool and ball rotation on the sheet is effective in this category. Also, less friction in the tool with rotating geometry can improve the surface smoothness. The results of the measurements of surface roughness by two parameters Ra and Rz for two instruments under test conditions are shown in Fig. 11. The results of this article are in good agreement with the results presented in the article by Honarpisheh [30].

\*Corresponding author

Email address: honarpishe@kashanu.ac.ir



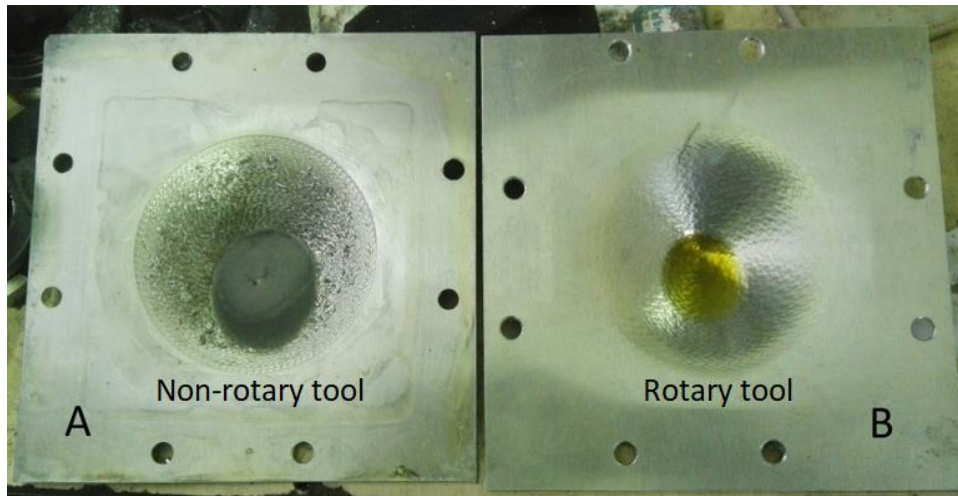

Fig. 10. The color of the used oil for two tool

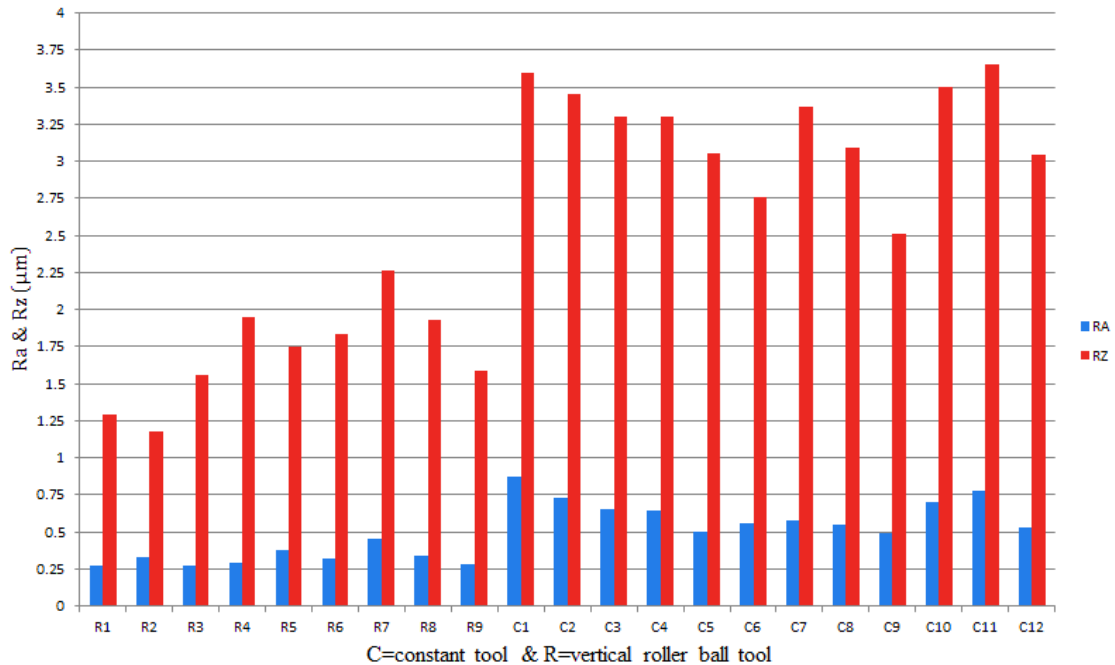

Fig. 11. Results of surface roughness

As it has been stated, the surface quality of the rotary tool is better than non-rotary tool. A distinct difference between the values in the above graph illustrates this issue.

#### 4.3. Effects of input parameters on the thickness distribution in the two type of the tools

The results of investigation of thickness distribution in the rotary and non-rotary tools

are indicated in the Fig. 12. According to the picture, rotary tool has less changes in the thickness distribution in compare with non-rotary tool. The non-rotary tool cut some of the material from surface of the sheet and by doing this work product maximum change in the maximum thickness distribution. Of course, the high friction in the non-rotating tool can also lead to inappropriate conditions in the thickness distribution. The results presented in references 11, 14 and 30 show a good agreement with the

\*Corresponding author

Email address: honarpishe@kashanu.ac.ir

results outlined in this paper about thickness distribution. The results obtained in these papers suggest that increasing the vertical step increases the maximum thickness variation.

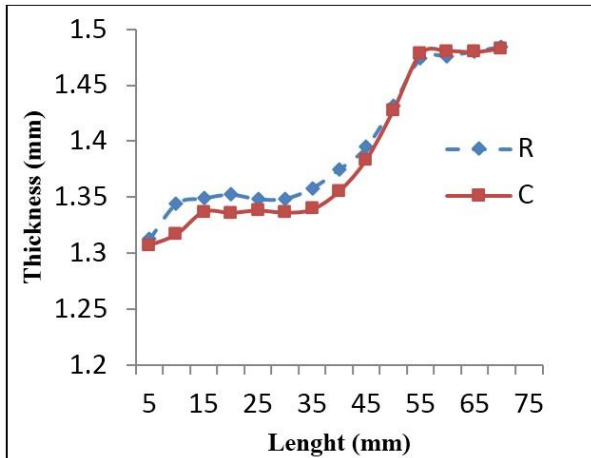

Fig. 12. The results of maximum thickness distribution

### 5. Conclusion

In this study the effect of spindle speed, step down, feed rate and design of forming tool have been investigated on the forming forces, surface roughness and thickness distribution during the incremental sheet metal forming and conclusions have been given below:

- Forming force increased by increasing step down and feed rate. Spindle speed had no significant effect on this parameter.
- In the same conditions, forming force decreased by using rotary tool due to the less friction in this model of the tool.
- Surface roughness increased by increasing vertical step and feed rate. Spindle speed had no significant effect on this parameter.
- The non- rotary tool destroyed surface roughness by cut some of the material from surface of the sheet.
- Maximum thickness changes increase with increasing vertical step and feed rate, which is due to increased strain.
- The thickness distribution in the rotary tool, due to the fact that there is less friction between the tool and the sheet and as well as not removing parts of the sheet by the tool has a better trend than the conventional tool.

### References

- [1] Jeswiet, J., F. Micari, G. Hirt, A. Bramley, Joost Dufloy, and J. Allwood. "Asymmetric single point incremental forming of sheet metal." *CIRP Annals-Manufacturing Technology*, Vol. 54, No. 2, pp. 88-114 (2005).
- [2] Jeswiet, J., E. Hagan, and A. Szekeres. "Forming parameters for incremental forming of aluminium alloy sheet metal." *Proceedings of the Institution of Mechanical Engineers, Part B: Journal of Engineering Manufacture*, Vol. 216, No.10, pp. 1367-1371(2002).
- [3] Silva, M. B., Pedro Teixeira, Ana Reis, and P. A. F. Martins. "On the formability of hole-flanging by incremental sheet forming." *Proceedings of the Institution of Mechanical Engineers, Part L: Journal of Materials Design and Applications*, Vol. 227, No. 2, pp. 91-99 (2013).
- [4] Montanari, L., V. A. Cristino, M. B. Silva, and P. A. F. Martins. "On the relative performance of hole-flanging by incremental sheet forming and conventional press-working." *Proceedings of the Institution of Mechanical Engineers, Part L: Journal of Materials Design and Applications*, Vol. 228, No. 4, pp. 312-322 (2014).
- [5] Ambrogio, G., L. Filice, and G. L. Manco. "Warm incremental forming of magnesium alloy AZ31." *CIRP Annals-Manufacturing Technology*, Vol. 57, No. 1 pp. 257-260 (2008).
- [6] Manco, G. L., and G. Ambrogio. "Influence of thickness on formability in 6082-T6." *International Journal of Material Forming* Vol. 3, No. 1 pp. 983-986 (2010).
- [7] Mirnia, M. J., B. Mollaei Dariani, H. Vanhove, and J. R. Dufloy. "An investigation into thickness distribution in single point incremental forming using sequential limit analysis." *International Journal of Material Forming*, Vol. 7, No. 4, pp. 469-477 (2014).
- [8] Hagan, E., and J. Jeswiet. "Analysis of surface roughness for parts formed by computer numerical controlled incremental forming." *Proceedings of the Institution of*

- Mechanical Engineers, Part B: Journal of Engineering Manufacture*, Vol. 218, No. 10, pp. 1307-1312 (2004).
- [9] Fratini, L., G. Ambrogio, R. Di Lorenzo, L. Filice, and F. Micari. "Influence of mechanical properties of the sheet material on formability in single point incremental forming." *CIRP Annals-Manufacturing Technology*, Vol. 53, No. 1 pp. 207-210 (2004).
- [10] Iseki, Hideo. "An approximate deformation analysis and FEM analysis for the incremental bulging of sheet metal using a spherical roller." *Journal of Materials Processing Technology*, Vol. 111, No. 1, pp. 150-154 (2001).
- [11] Iseki, Hideo, and Takashi Naganawa. "Vertical wall surface forming of rectangular shell using multistage incremental forming with spherical and cylindrical rollers." *Journal of materials processing technology*, Vol. 130, pp. 675-679 (2002).
- [12] Filice, L., L. Fratini, and F. Micari. "Analysis of material formability in incremental forming." *CIRP annals-Manufacturing technology*, Vol. 51, No. 1, pp. 199-202 (2002).
- [13] Attanasio, A., E. Ceretti, and C. Giardini. "Optimization of tool path in two points incremental forming." *Journal of Materials Processing Technology*, Vol. 177, No. 1, pp. 409-412 (2006).
- [14] Young, D., and J. Jeswiet. "Wall thickness variations in single-point incremental forming." *Proceedings of the Institution of Mechanical Engineers, Part B: Journal of Engineering Manufacture*, Vol. 218, No. 11, pp. 1453-1459 (2004).
- [15] Hussain, G., L. Gao, and Z. Y. Zhang. "Formability evaluation of a pure titanium sheet in the cold incremental forming process." *The International Journal of Advanced Manufacturing Technology*, Vol. 37, No. 9-10, pp. 920-926 (2008).
- [16] Hamilton, K., and J. Jeswiet. "Single point incremental forming at high feed rates and rotational speeds: Surface and structural consequences." *CIRP Annals-Manufacturing Technology*, Vol. 59, No. 1, pp. 311-314 (2010).
- [17] Kurra, Suresh, Srinivasaparakash Regalla, and Amit Kumar Gupta. "Parametric study and multi-objective optimization in single-point incremental forming of extra deep drawing steel sheets." *Proceedings of the Institution of Mechanical Engineers, Part B: Journal of Engineering Manufacture*, Vol. 230, No. 5, pp. 825-837 (2016).
- [18] Bao, Wenke, Xingrong Chu, Shuxia Lin, and Jun Gao. "Experimental investigation on formability and microstructure of AZ31B alloy in electropulse-assisted incremental forming." *Materials & Design*, Vol. 87, pp. 632-639, (2015).
- [19] Suresh, Kurra, and Srinivasa Prakash Regalla. "Analysis of formability in single point incremental forming using finite element simulations." *Procedia Materials Science*, Vol. 6, pp. 430-435, (2014).
- [20] Senthil, R., and A. Gnanavelbabu. "Numerical analysis on formability of AZ61A magnesium alloy by incremental forming." *Procedia Engineering*, Vol. 97, pp. 1975-1982 (2014).
- [21] Mugendiran, V., and A. Gnanavelbabu. "Comparison of FLD and thickness distribution on AA5052 aluminium alloy formed parts by incremental forming process." *Procedia Engineering*, Vol. 97 pp. 1983-1990 (2014).
- [22] McAnulty, Tegan, Jack Jeswiet, and Matthew Doolan. "Formability in single point incremental forming: A comparative analysis of the state of the art.", *CIRP Journal of Manufacturing Science and Technology*, Vol. 16, pp. 43-54 (2017).
- [23] EH. Uheida, G. A. Oosthuizen, and D. Dimitrov, "Investigating the Impact of Tool Velocity on the Process Conditions in Incremental Forming of Titanium Sheets", *Procedia Manufacturing* Vol. 7, pp. 345-350 (2016).
- [24] D. Afonso, R. Alves de Sousa, and R. Torcato, "Incremental Forming of Tunnel Type Parts", *Procedia Engineering*, Vol. 183, pp. 137-142, (2017).
- [25] MR. Sakhtemanian, M. Honarpisheh, and S. Amini, "Numerical and experimental study

- on the layer arrangement in the incremental forming process of explosive-welded low-carbon steel/CP-titanium bimetal sheet", *The International Journal of Advanced Manufacturing Technology*, Vol. 95, No. 9, pp. 3781-3796, (2018).
- [26] M. Honarpisheh, and A. Gheysarian, "An Experimental Study on the process parameters of Incremental Forming of Explosively-Welded Al/Cu Bimetals", *Journal of Computational & Applied Research in Mechanical Engineering*, Vol. 7, No. 1, pp. 73-83, (2017).
- [27] M. Honarpisheh, M. Mohammadi Jobedar, and I. Alinaghian, "Multi-response optimization on single-point incremental forming of hyperbolic shape Al-1050/Cu bimetal using response surface methodology", *The International Journal of Advanced Manufacturing Technology*, Vol. 96, No. 9-12, pp.3069-3080, (2018).
- [28] M. Honarpisheh, M. Keimasi, and I. Alinaghian, "Numerical and experimental study on incremental forming process of Al/Cu bimetals: influence of process parameters on the forming force, dimensional accuracy and thickness variations", *Journal of Mechanics of Materials and Structures* Vol. 13, pp. 35-51, (2018).
- [29] M. Honarpisheh, M. J. Abdolhoseini, and S. Amini, "Experimental and numerical investigation of the hot incremental forming of Ti-6Al-4V sheet using electrical current", *The International Journal of Advanced Manufacturing Technology*, Vol. 83, No. 9-12 pp. 2027-2037, (2016).
- [30] A. Gheysarian, and M. Honarpisheh, "Process Parameters Optimization of the Explosive-Welded Al/Cu Bimetal in the Incremental Sheet Metal Forming Process." *Iranian Journal of Science and Technology, Transactions of Mechanical Engineering*: pp. 1-12, (2018).
- [31] Sakhtemanian, M. R., M. Honarpisheh, and S. Amini. "A novel material modeling technique in the single-point incremental forming assisted by the ultrasonic vibration of low carbon steel/commercially pure titanium bimetal sheet." *The International Journal of Advanced Manufacturing Technology*, 1-14, (2019).
- [32] Sakhtemanian, M. R., S. Amini, and M. Honarpisheh. "Simulation and investigation of mechanical and geometrical properties of St/CP-titanium bimetal sheet during the single point incremental forming process." *Iranian Journal of Materials Forming* 5, no. 1, 1-18, (2018).